

# DAQPAD CABLE ADAPTER

Thank you for purchasing the DAQPad cable adapter from National Instruments. This guide describes how to install the adapter to connect the DAQPad-MIO-16XE-50 to external accessories.

The DAQPad cable adapter contains the shielded 68-pin E Series I/O connector that connects the DAQPad-MIO-16XE-50 to accessories such as the SCB-68 and the SC-2040 Series. The adapter also contains spring terminals for connection to external current excitation and a temperature sensor for cold-junction compensation with thermocouples. Figure 1 shows the DAQPad cable adapter parts locator diagram.

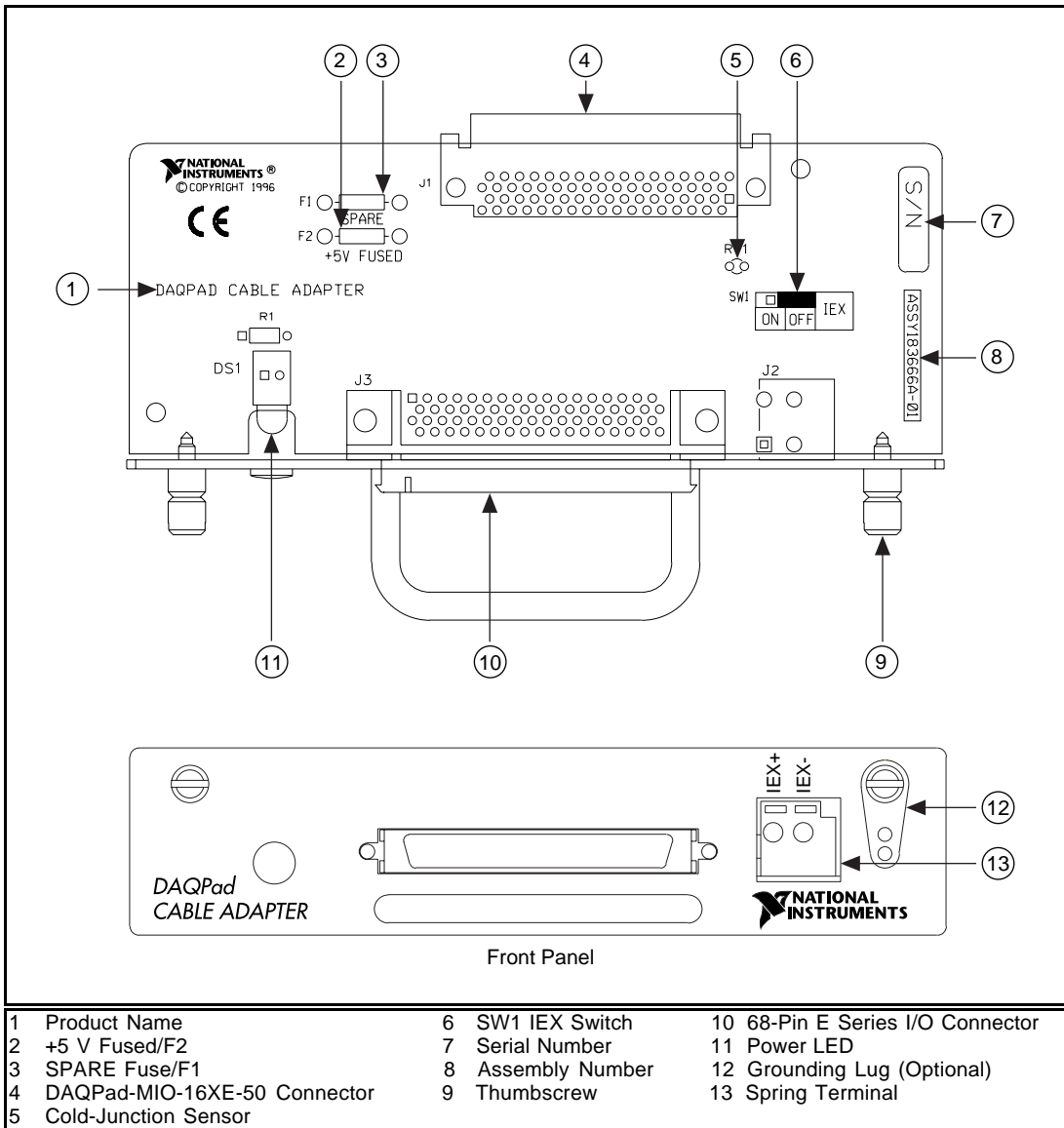

Figure 1. Parts Locator Diagram

## +5 V Fuses

There are two fuses on the adapter. The fuse labeled *+5 V FUSED/F2* limits the +5 V power output current. The fuse labeled *SPARE FUSE/F1* is a replacement.

## Grounding Lug

If you are using a shielded cable for external current excitation, you can install a grounding lug to connect the cable shield to the chassis ground of the DAQPad-MIO-16XE-50. Two grounding lugs are included in your adapter kit; one of these is a spare.

To install a lug, remove the thumbscrew nearest the spring terminals. Put the thumbscrew through the hole in the lug and reinstall the thumbscrew, as shown in Figure 1.

## IEX Spring Terminals

The spring terminals on the front panel, IEX+ and IEX-, provide external current excitation for temperature measurements using RTDs or thermistors. IEX+ is the current output and IEX- is the current return. The constant current source provides 100  $\mu$ A of external excitation.

To connect to the spring terminal blocks, you can use up to 20 AWG wire with the insulation stripped to 0.5 in. Depress the orange lever using a small screwdriver, then insert the wire and release the lever.

The IEX slide switch, SW1, turns external current excitation on and off. For external current excitation, push SW1 to the ON position.

Figure 2 suggests how you can connect several RTDs in series to the DAQPad-MIO-16XE-50 using four-wire measurement techniques.



**Note:** *If you do not externally connect IEX+ to IEX- and you want to perform cold-junction sensor measurements, you must push the slide switch to the OFF position.*

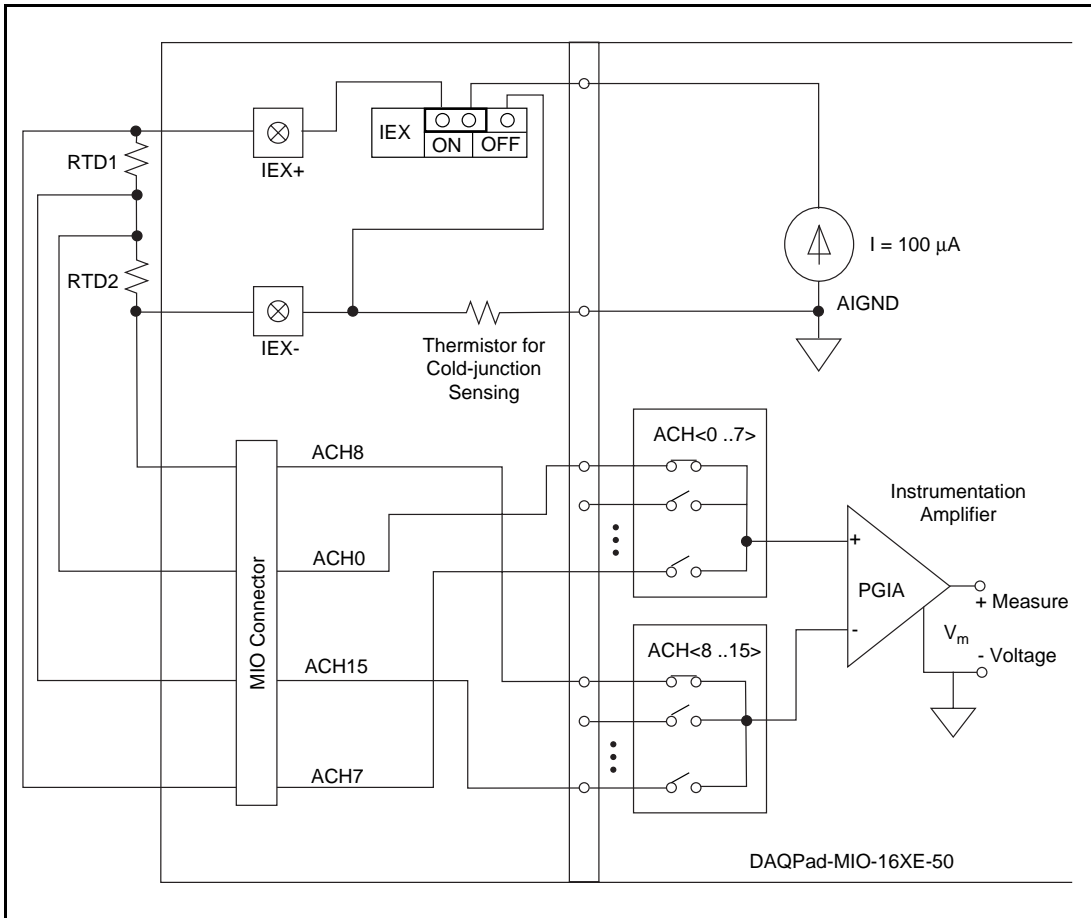

Figure 2. RTD Connection Using External Current Excitation

# Pin Assignments

Figure 3 shows the pin assignments of the DAQPad cable adapter.

ACH8	34	68	ACH0
ACH1	33	67	AIGND
AIGND	32	66	ACH9
ACH10	31	65	ACH2
ACH3	30	64	AIGND
AIGND	29	63	ACH11
ACH4	28	62	AISENSE
AIGND	27	61	ACH12
ACH13	26	60	ACH5
ACH6	25	59	AIGND
AIGND	24	58	ACH14
ACH15	23	57	ACH7
DAC0OUT	22	56	AIGND
DAC1OUT	21	55	AOGND
EXTREF	20	54	AOGND
DIO4	19	53	DGND
DGND	18	52	DIO0
DIO1	17	51	DIO5
DIO6	16	50	DGND
DGND	15	49	DIO2
+5 V	14	48	DIO7
DGND	13	47	DIO3
DGND	12	46	SCANCLK
PFI0/TRIG1	11	45	EXTSTROBE*
PFI1/TRIG2	10	44	DGND
DGND	9	43	PFI2/CONVERT*
+5 V	8	42	PFI3/GPCTR1_SOURCE
DGND	7	41	PFI4/GPCTR1_GATE
PFI5/UPDATE*	6	40	GPCTR1_OUT
PFI6/WFTRIG	5	39	DGND
DGND	4	38	PFI7/STARTSCAN
PFI9/GPCTR0_GATE	3	37	PFI8/GPCTR0_SOURCE
GPCTR0_OUT	2	36	DGND
FREQ_OUT	1	35	DGND

Figure 3. DAQPad Cable Adapter Pin Assignments



**Warning:** *Connections that exceed any of the maximum ratings of input or output signals on the DAQPad-MIO-16XE-50 can damage the DAQPad-MIO-16XE-50 and the computer. The DAQPad-MIO-16XE-50 User Manual lists the maximum input ratings for each signal. National Instruments is NOT liable for any damages resulting from incorrect signal connections.*

## Installation

---

To install the DAQPad cable adapter, remove the DAQPad-TB-52 (a detachable terminal block with screw terminals) from the DAQPad-MIO-16XE-50. Slide the cable adapter into the DAQPad-MIO-16XE-50 and screw it in place using the two thumbscrews.



**Note:** *The LED on the DAQPad cable adapter lights only when the adapter is firmly connected to the DAQPad-MIO-16XE-50.*

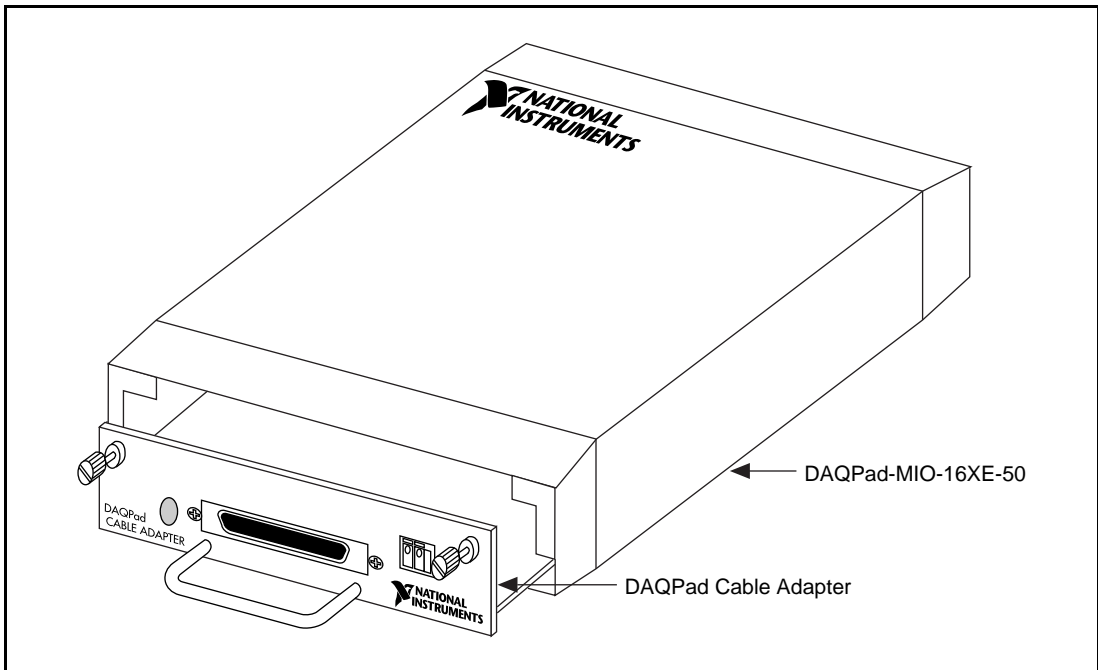

Figure 4. DAQPad-MIO-16XE-50

Refer to your *DAQPad-MIO-16XE-50 User Manual* for instructions on connecting your parallel port connectors and power supply to the DAQPad-MIO-16XE-50.